

# IMPACT 80 LØFTEVOGNE & VÆRKTØJ

- TEGNINGER & MÅL

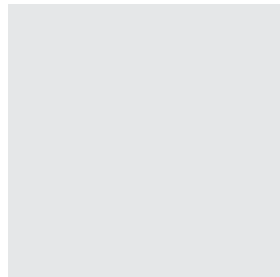
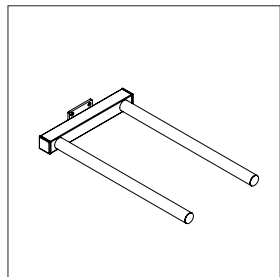
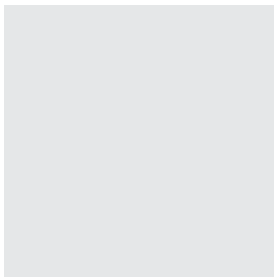
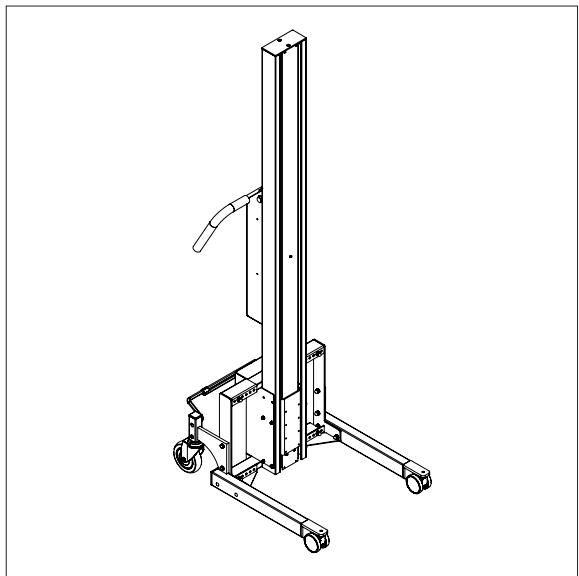
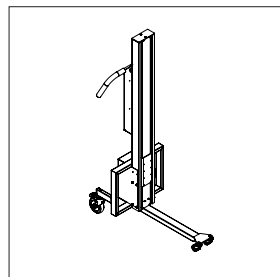
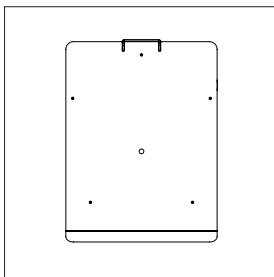
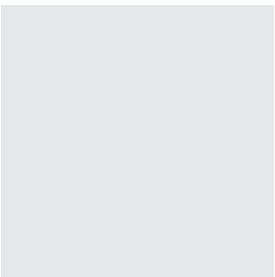
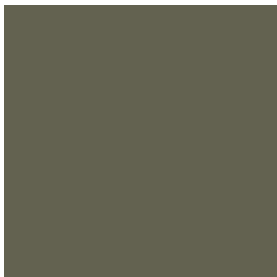
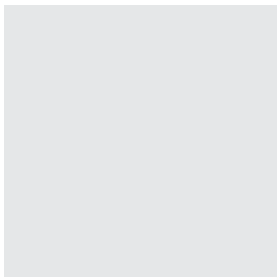

# IMPACT 80

## 2 MASTEHØJDER OG 15 BEN/HJUL OPTIONER

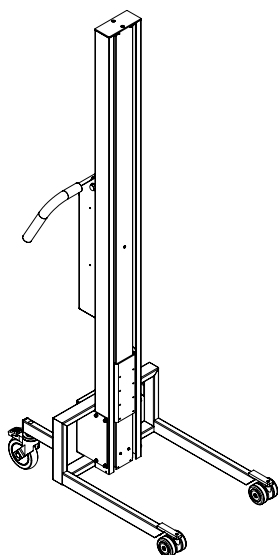

80 L/M standard ben

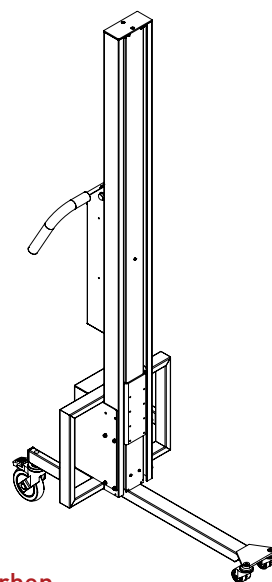

80 L/M Centerben

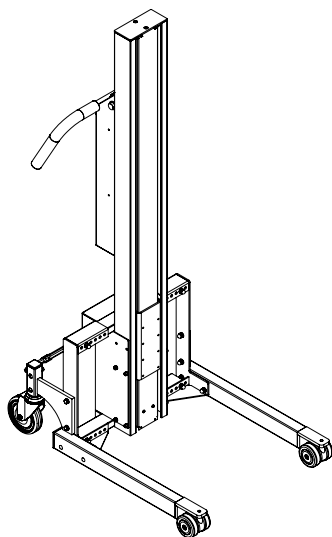

80 L/M FC - Flexben type 1

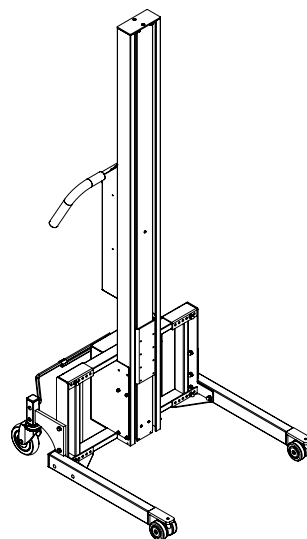

80 L/M FC - Flexben type 2

# IMPACT 80

## LØFTEVOGNE - TEGNINGER & MÅL

- Alle mål i mm

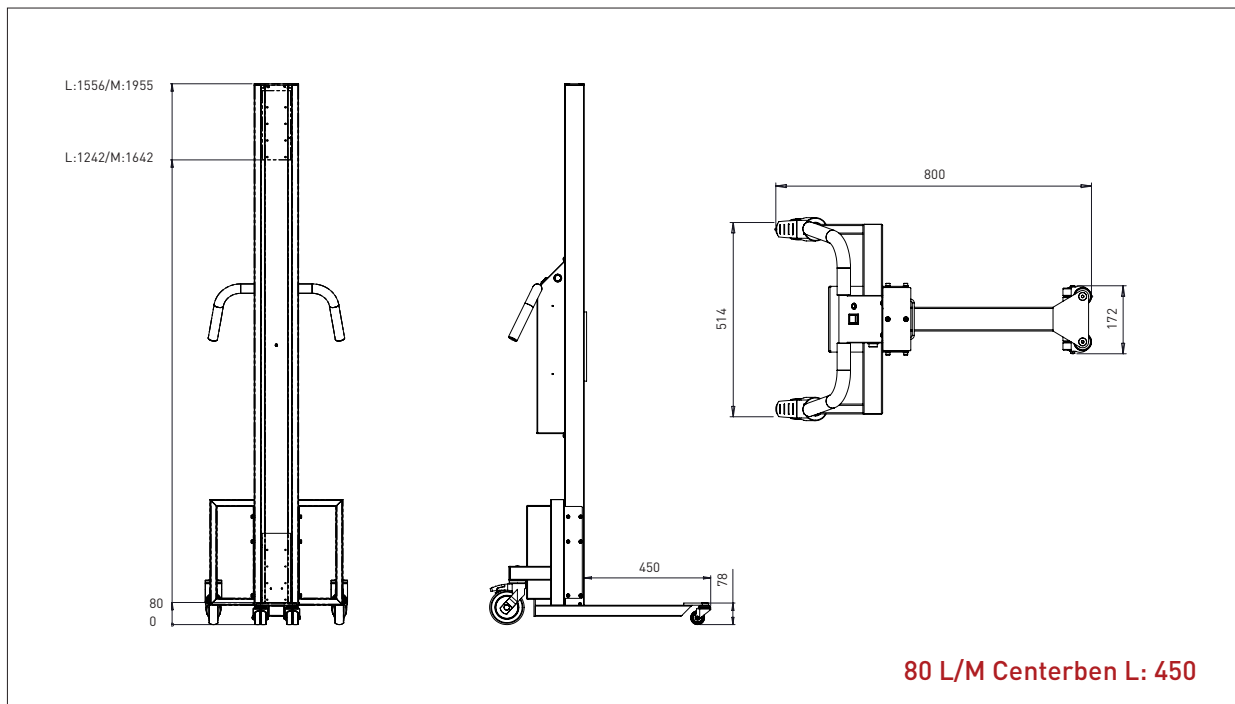
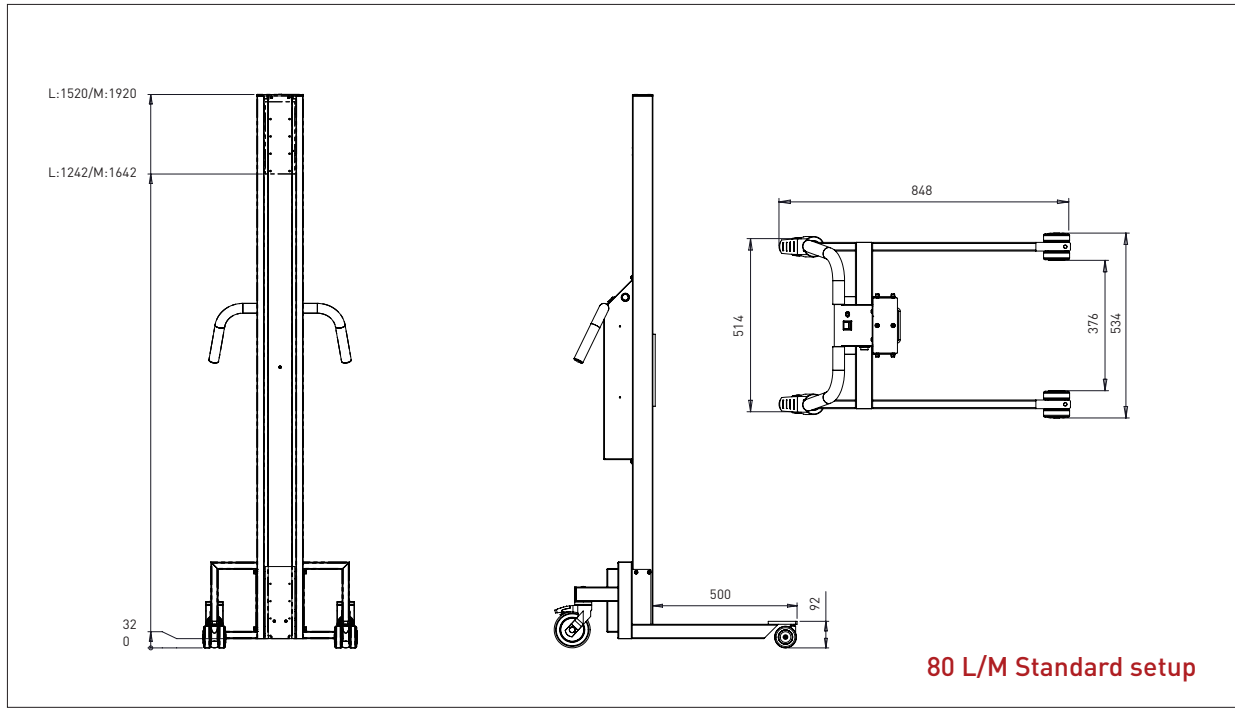

# IMPACT 80

## LØFTEVOGNE - TEGNINGER & MÅL

- Alle mål i mm

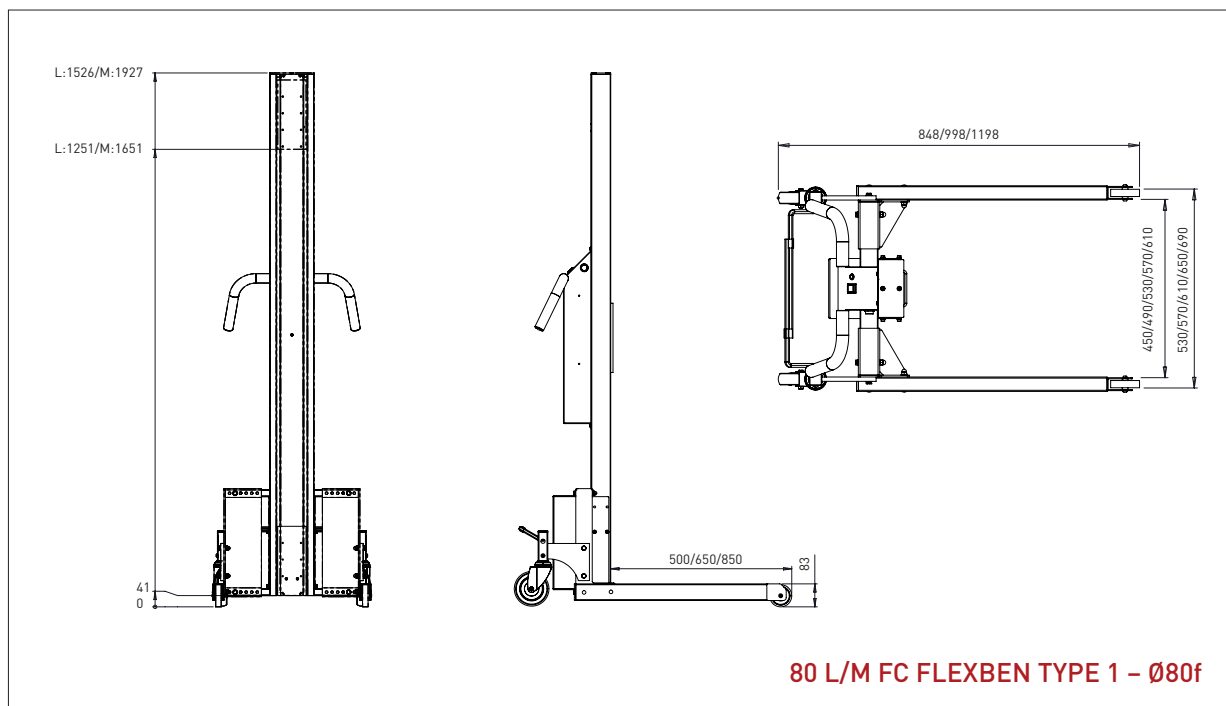
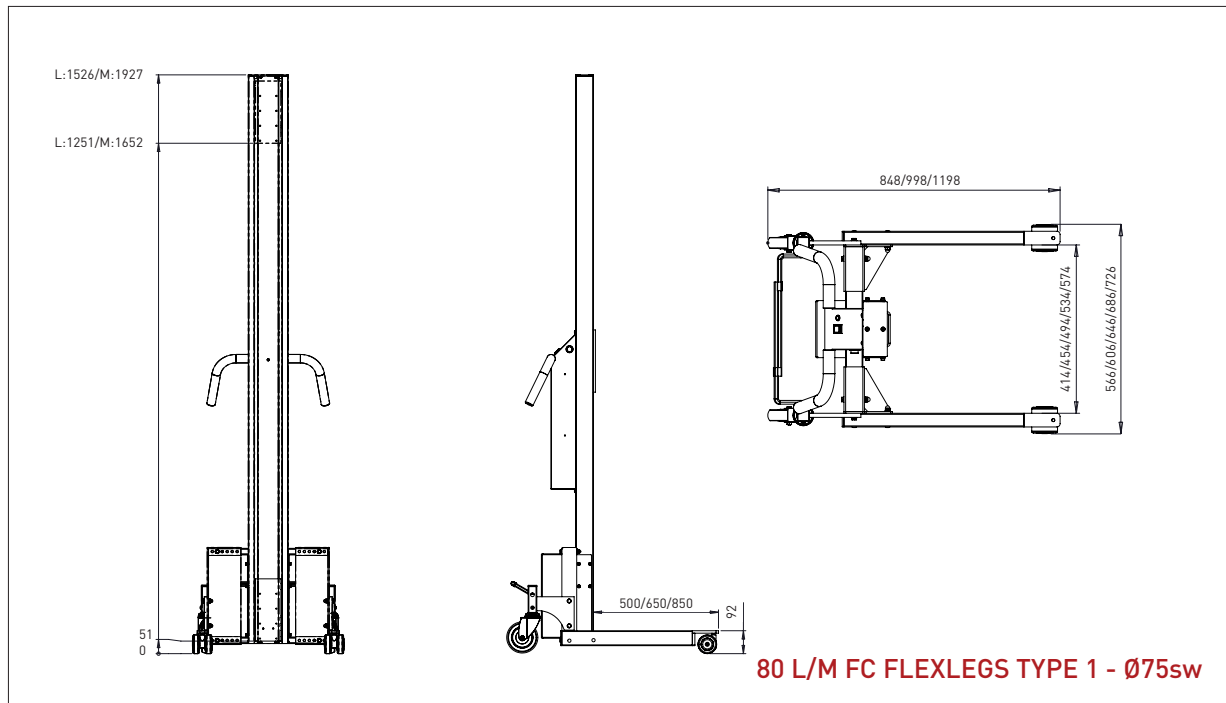

# IMPACT 80

## LØFTEVOGNE - TEGNINGER & MÅL

- Alle mål i mm

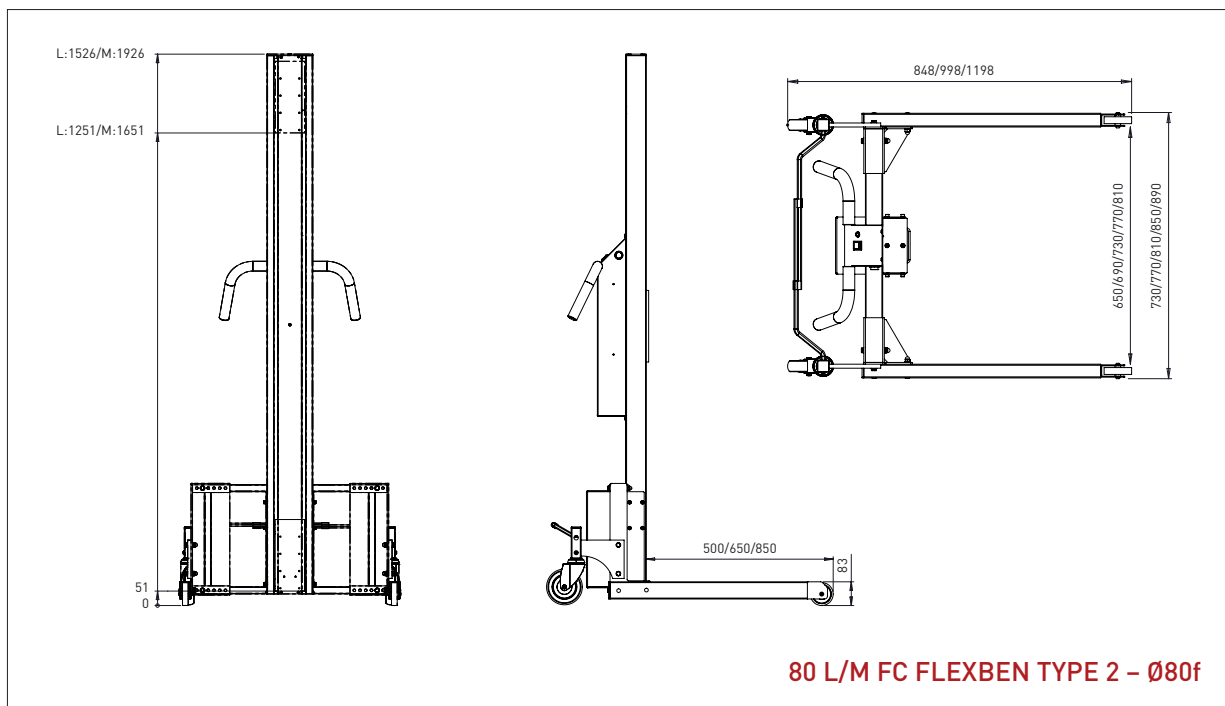
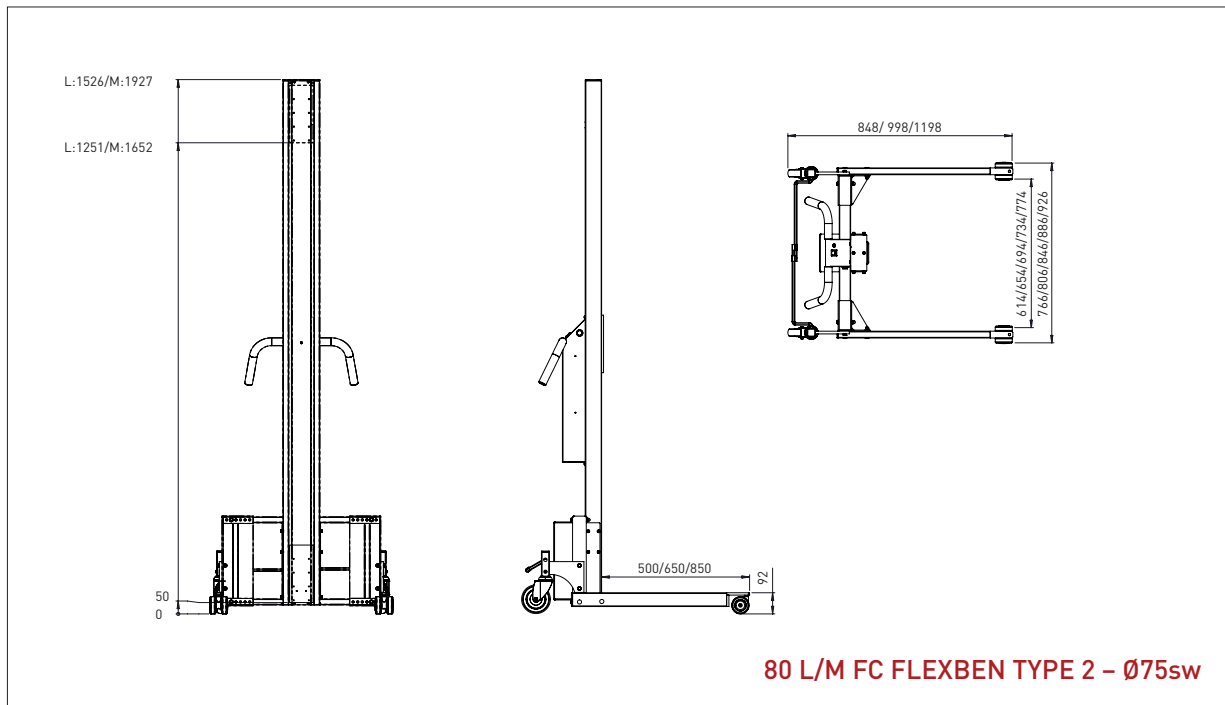

# IMPACT 80 / VÆRKTØJ

## TRÆPLADE

- Alle mål i mm

### TRÆPLADE - W1

L x B: 400 x 450 mm

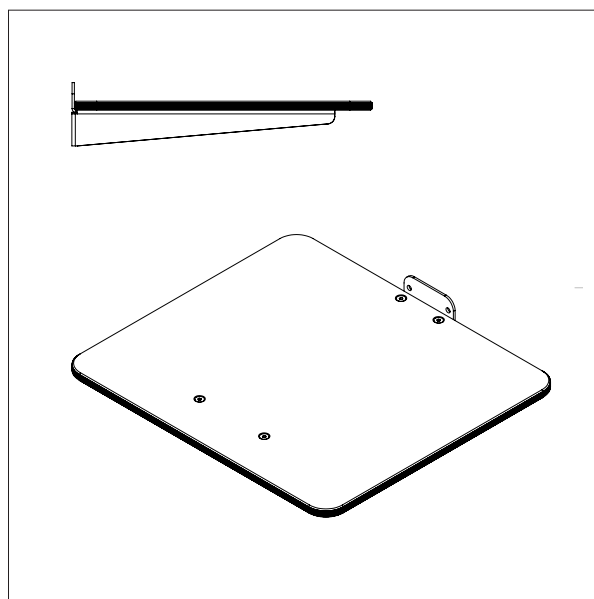
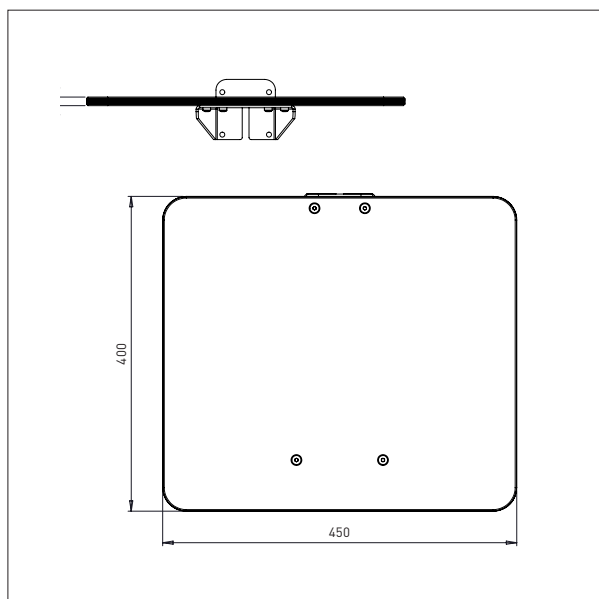

### TRÆPLADE - W2

L x B: 500 x 500 mm

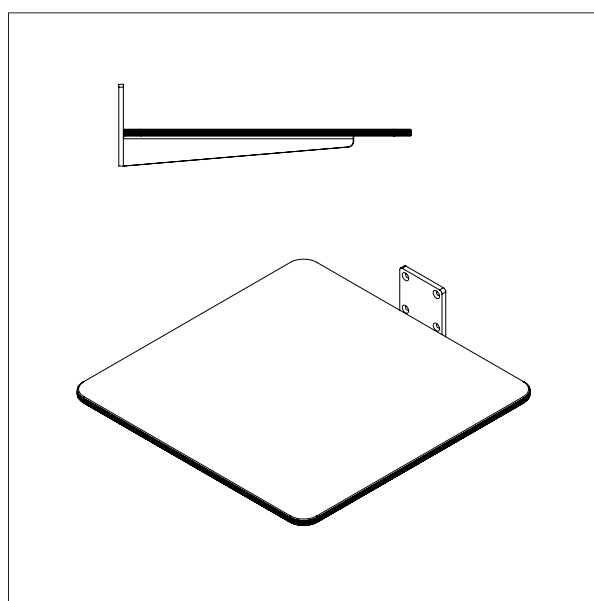
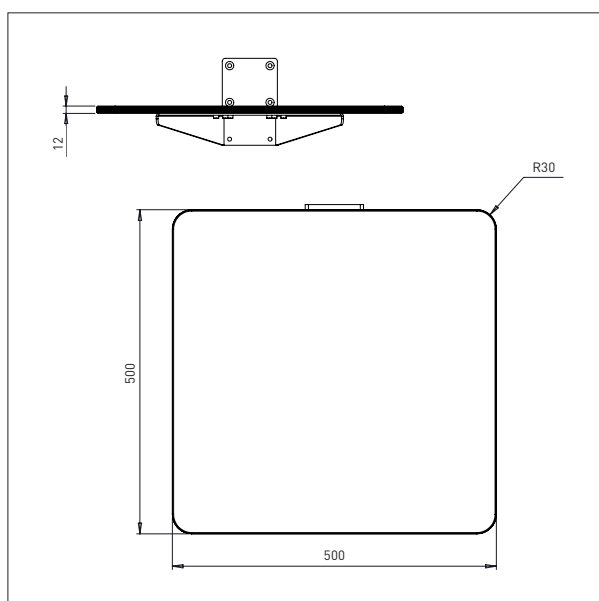

# IMPACT 80 / VÆRKTØJ

## TRÆPLADE

- Alle mål i mm

### TRÆPLADE - W3

L x B: 600 x 600 mm

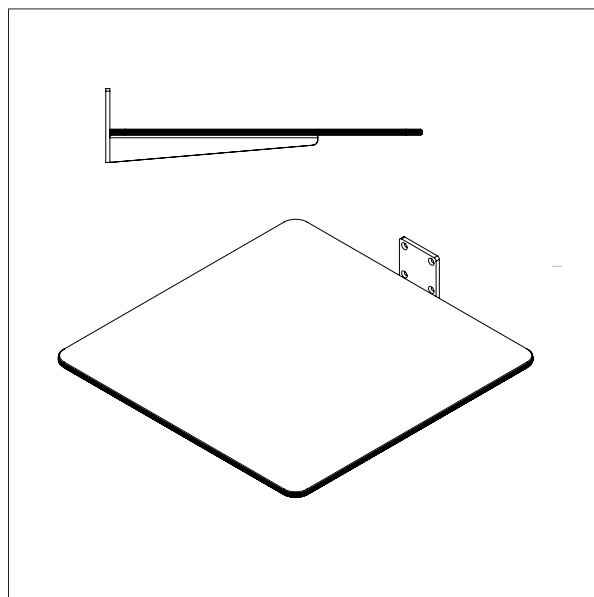
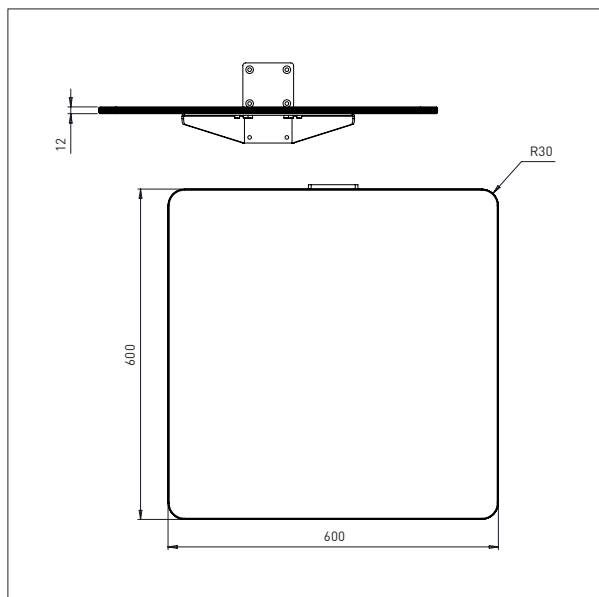

### TRÆPLADE - W4

L x B: 500 x 500 mm

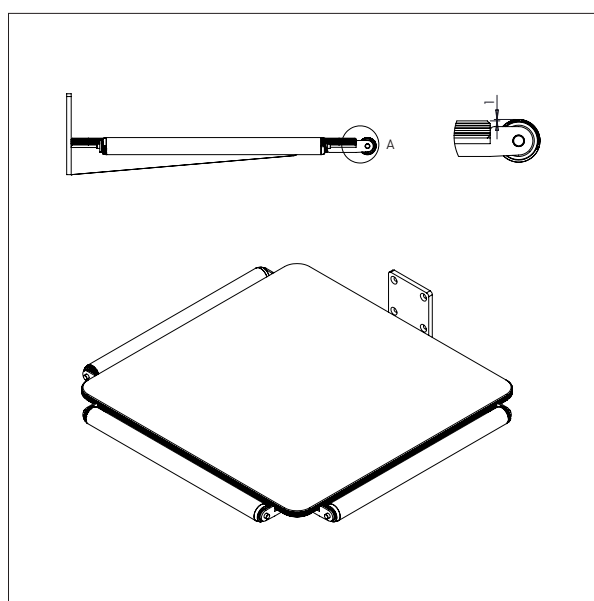
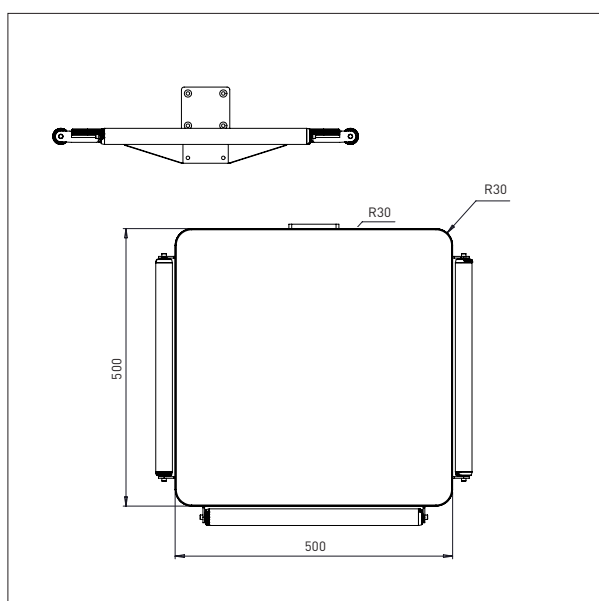

# IMPACT 80 / VÆRKTØJ

## PEHD PLADE (PLASTIK)

- Alle mål i mm

### PEHD PLADE - KP1

L x B: 495 x 495 mm

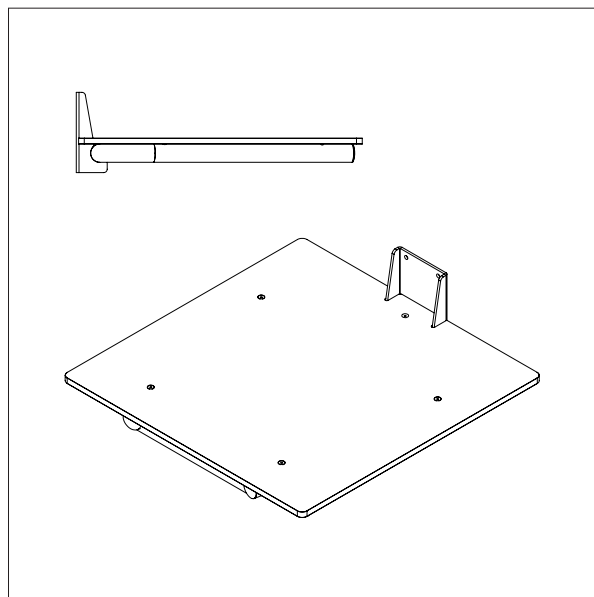
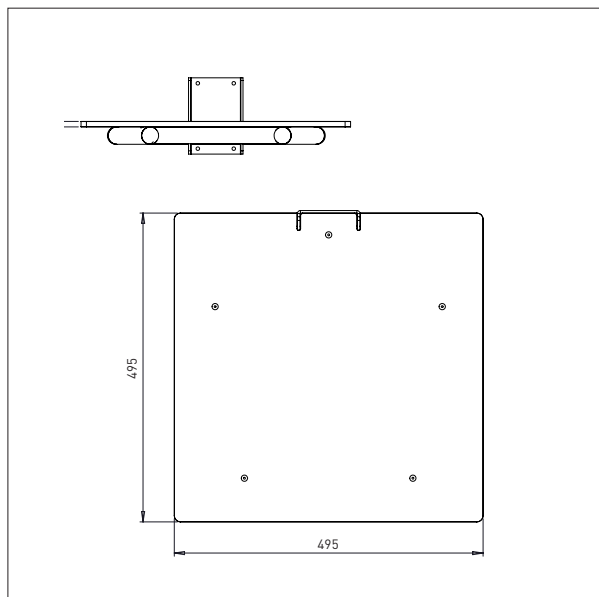

### PEHD PLADE - KP2

L x B: 600 x 600 mm

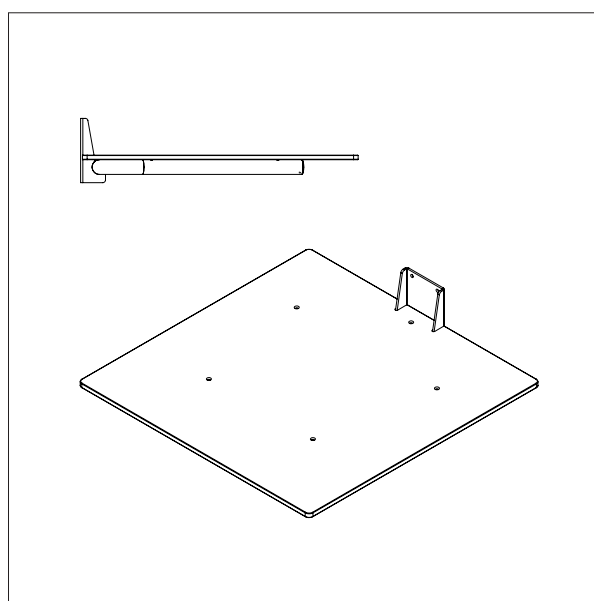
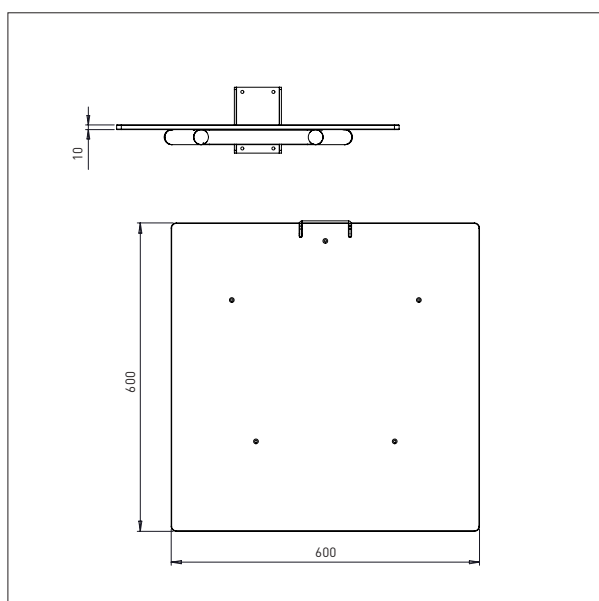



# IMPACT 80 / VÆRKTØJ

## PEHD PLADE (PLASTIK)

- Alle mål i mm

### PEHD PLADE MED RULLER – KP3

L x B: 495 x 495 mm

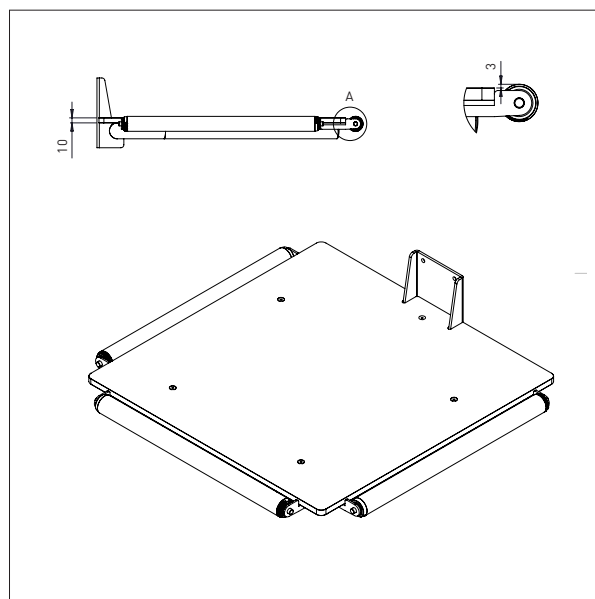
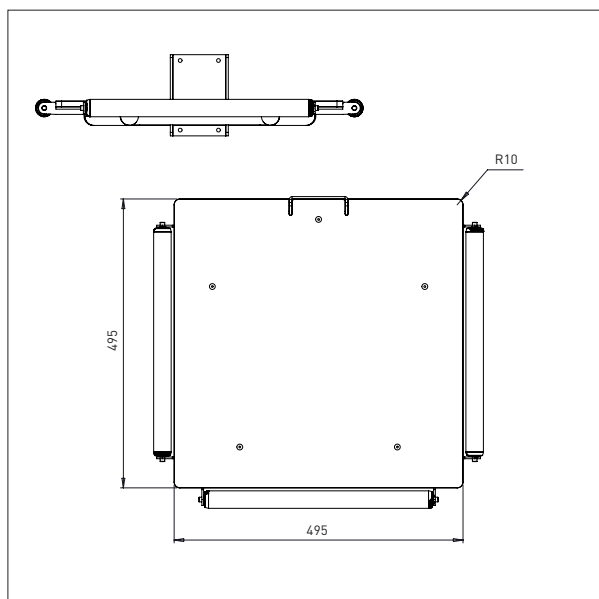

# IMPACT 80 / VÆRKTØJ

## RUSTFRI PLADE

- Alle mål i mm

### RUSTFRI PLADE - EP1

L x B: 500 x 400 mm

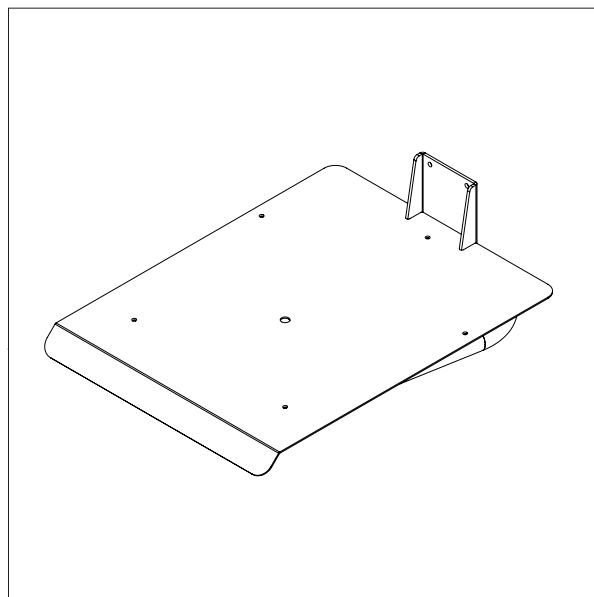
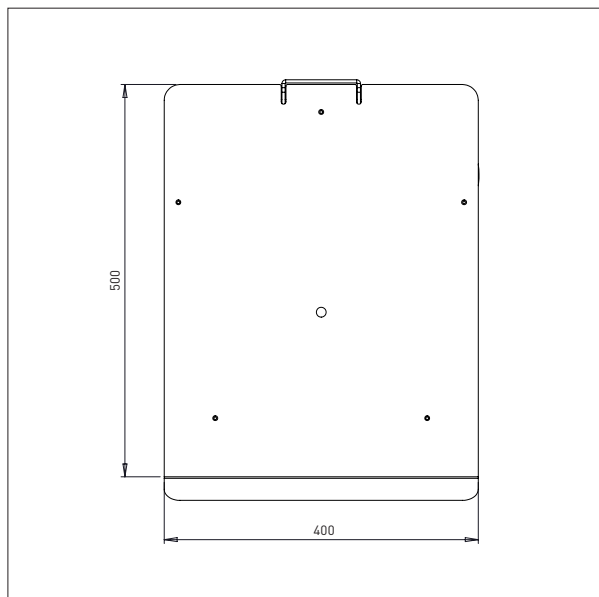

### RUSTFRI PLADE- EP2

L X B: 500 X 500 MM

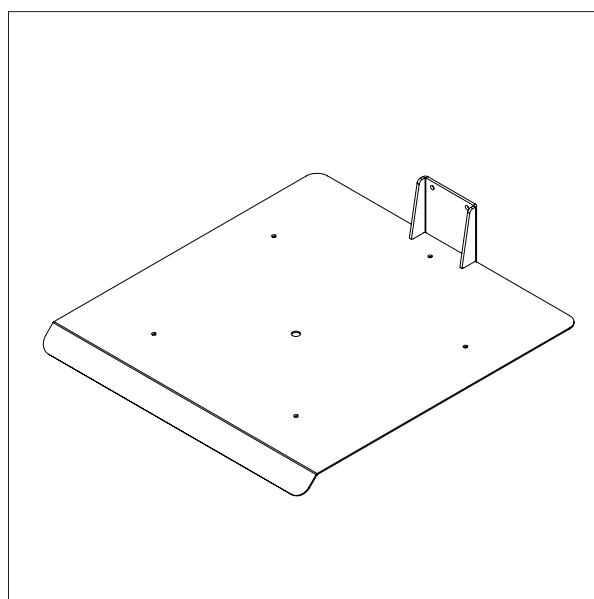
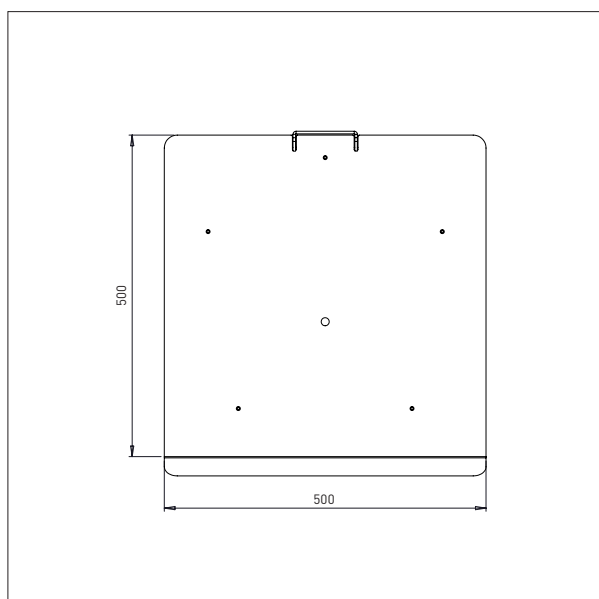

# IMPACT 80 / VÆRKTØJ

## DORN

- Alle mål i mm

### DORN - D1

Ø x L: 60 x 500 mm

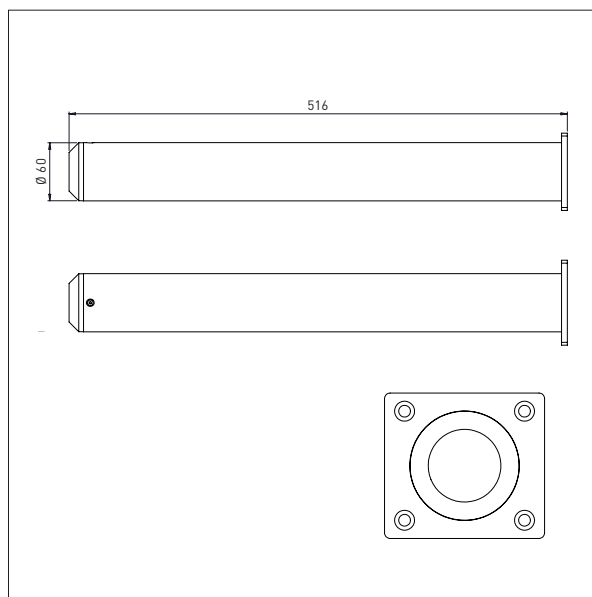
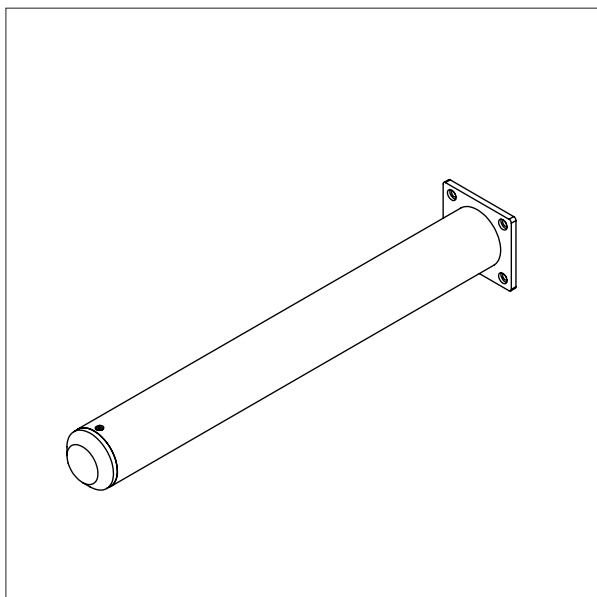

### DORN - D2

Ø x L: 60 x 800 mm

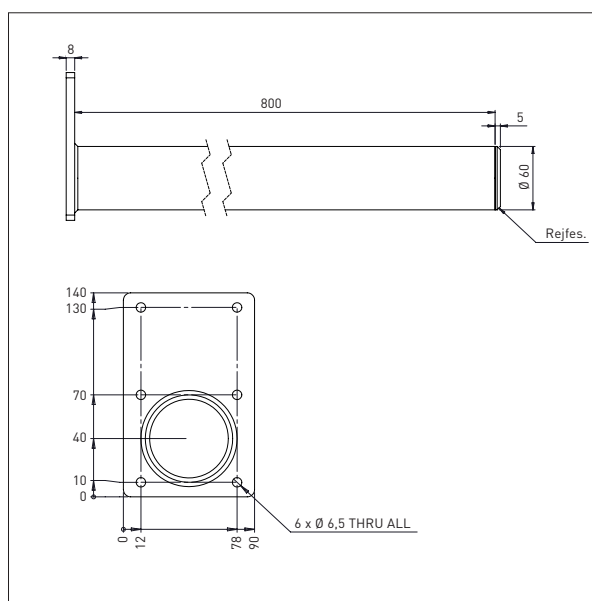
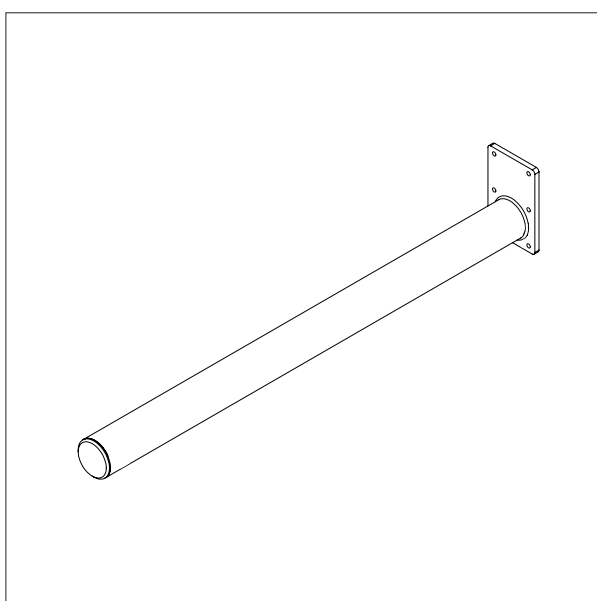

# IMPACT 80 / VÆRKTØJ

## DOBBELTDORN

- Alle mål i mm

### DOBBELTDORN – DD1

Ø x L x B: 32 x 500 x 250 mm

Min. bredde af rulle: Ø 300 mm

Max. bredde af rulle: Ø 400 mm

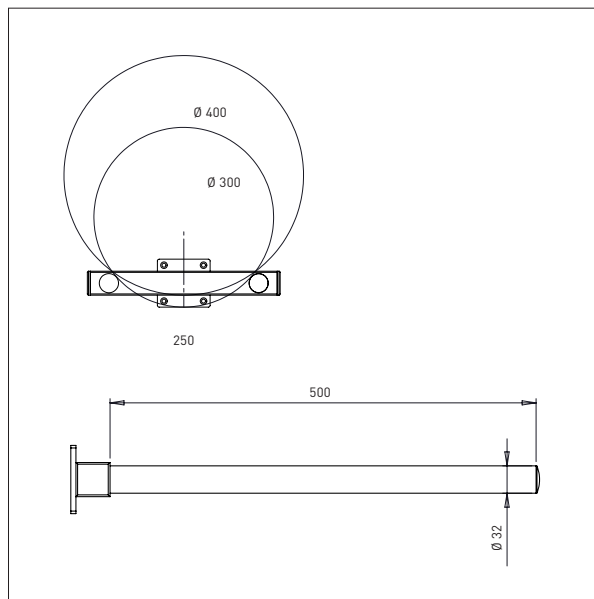
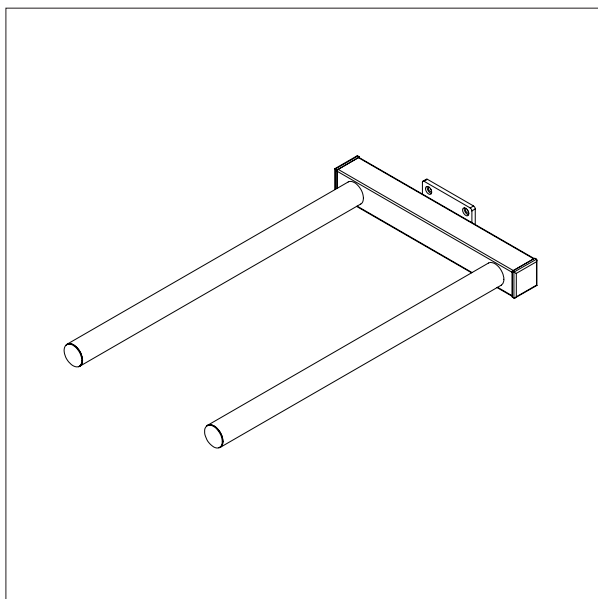

### DOBBELTDORN – DD2

Ø x L x B: 32 x 500 x 350 mm

Min. bredde af rulle: Ø 400 mm

Max. bredde af rulle: Ø 800 mm

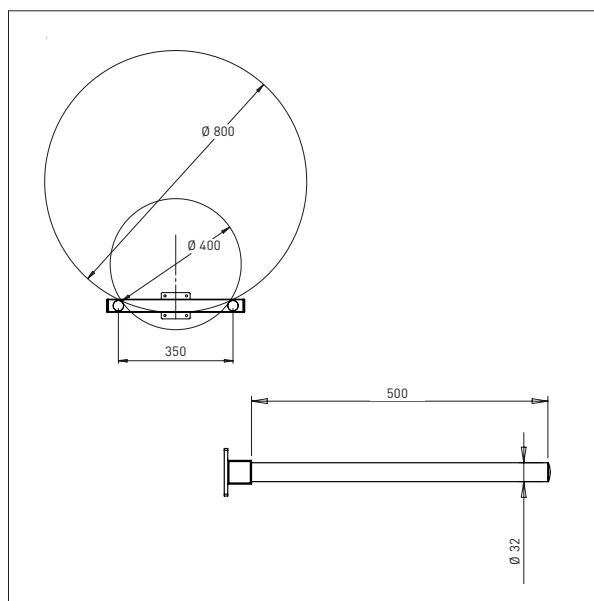
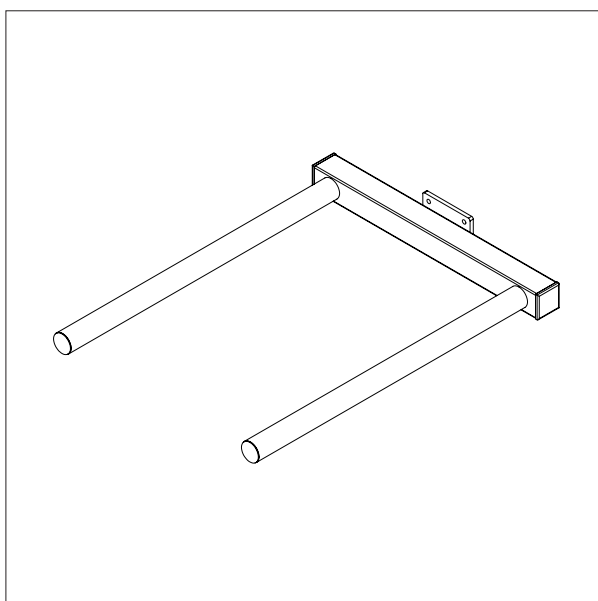

# IMPACT 80 / VÆRKTØJ

## GAFFEL

- Alle mål i mm

### GAFFEL - G1

L x B: 585 x 375 mm

Til 600 x 400 mm kasser

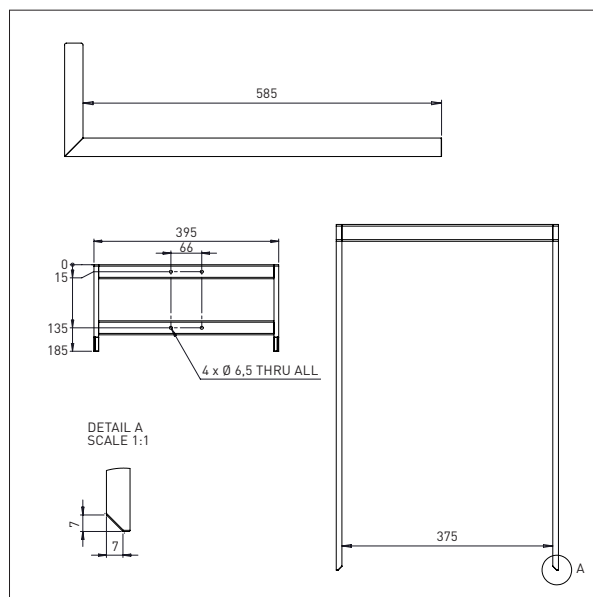
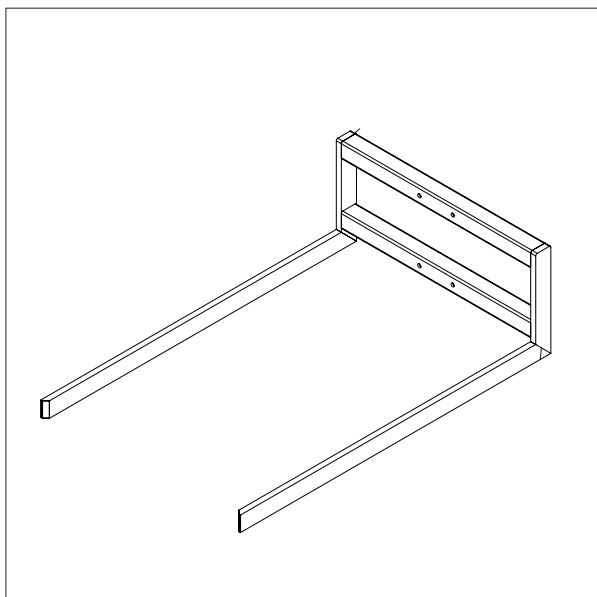

### GAFFEL - KLT

L x B: 600 x 410 mm

Til 600 x 400 mm kasser

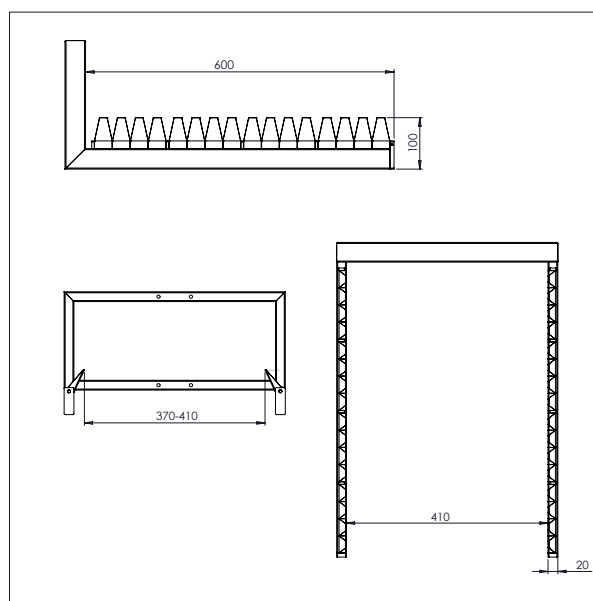
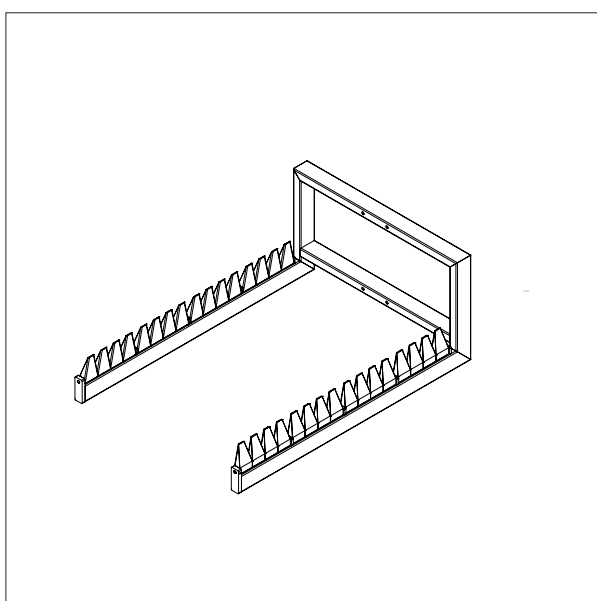

# IMPACT 80 / VÆRKTØJ

## DORN + V-BLOCK

- Alle mål i mm

### DORN + V-BLOCK – DVB1

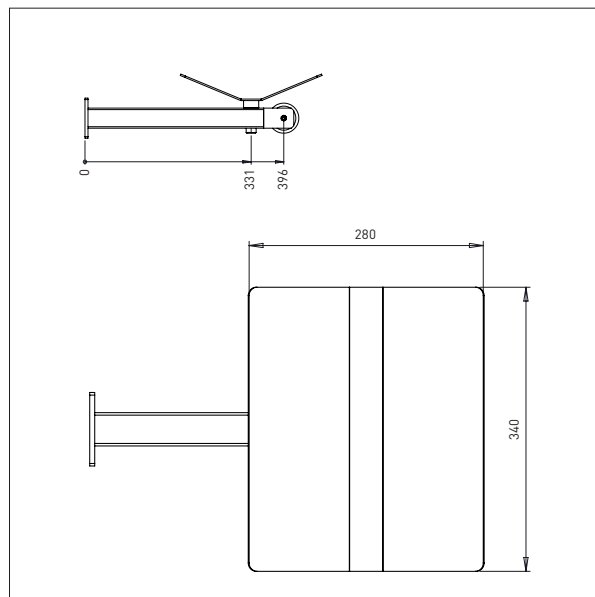
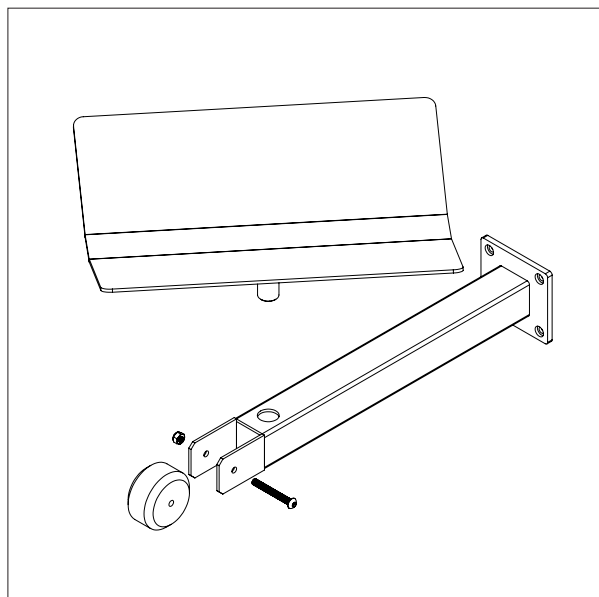

### DORN + V-BLOCK – DVB2

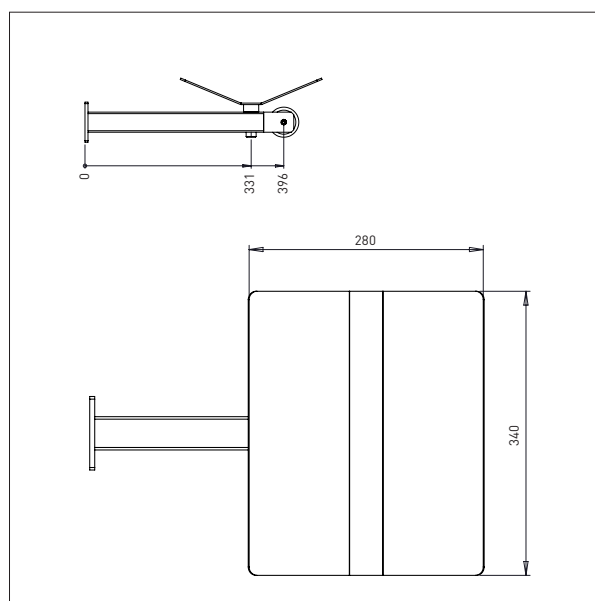
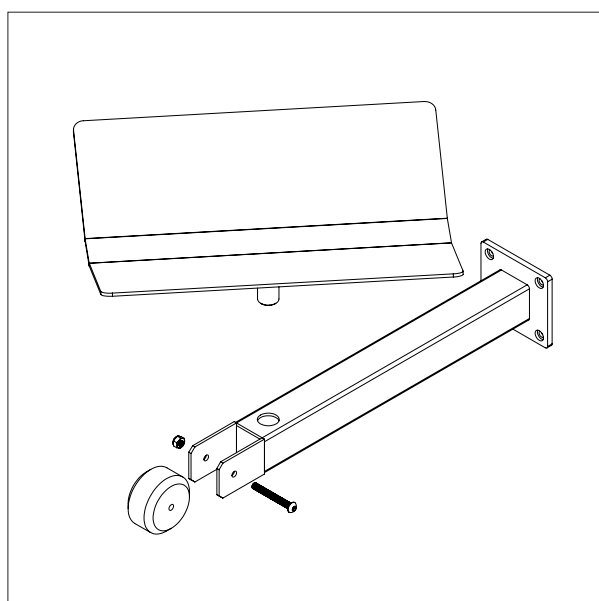

# IMPACT 80 / VÆRKTØJ

## PLADE + V-BLOCK

- Alle mål i mm

PLADE + V-BLOCK - EPV

PLADE: 500 X 400

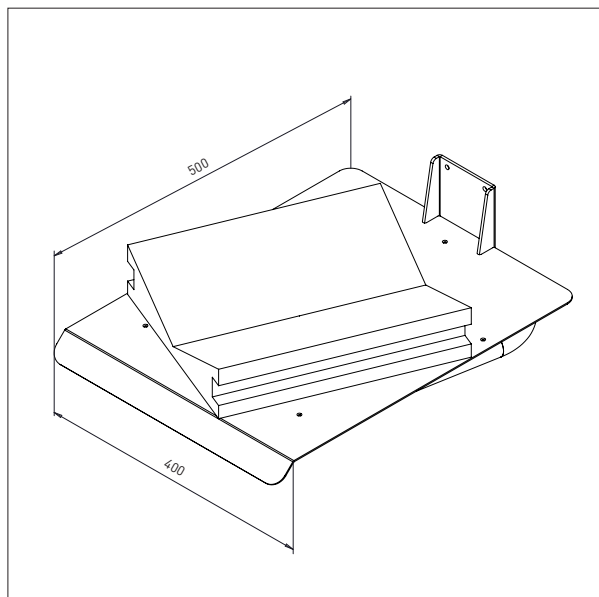

# IMPACT 80 / VÆRKTØJ

## KRANARM

- Alle mål i mm

### KRANARM - KA1

L: 600

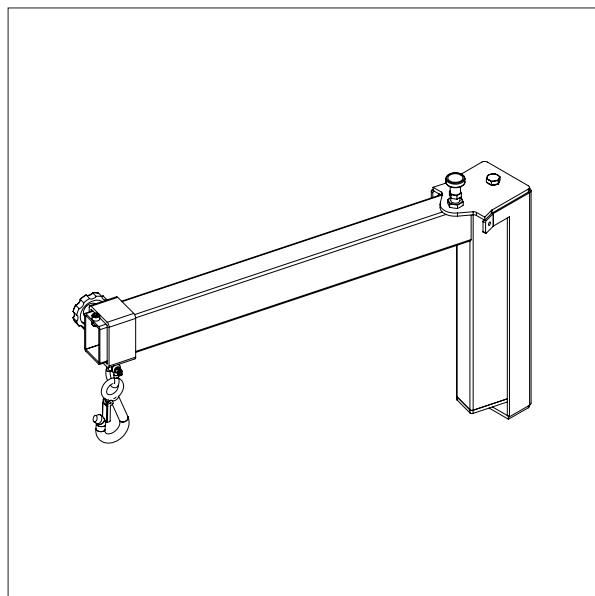
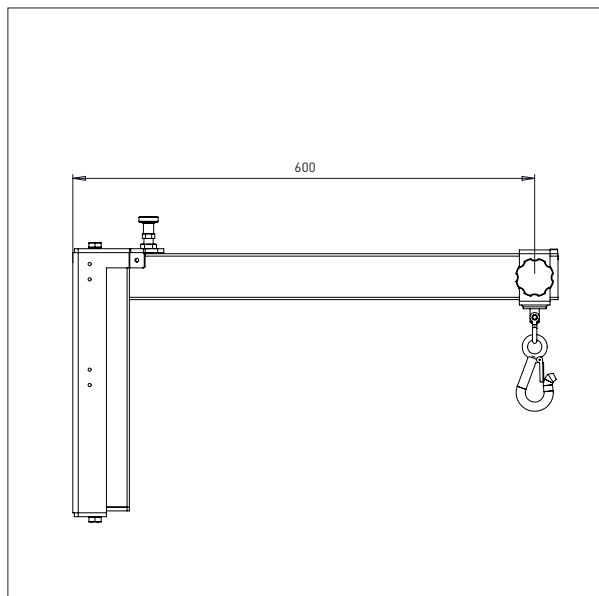

### KRANARM - KA2

L: 800

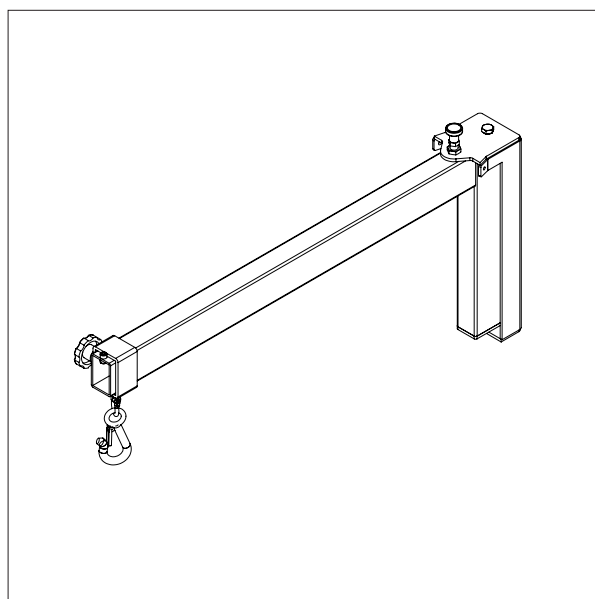
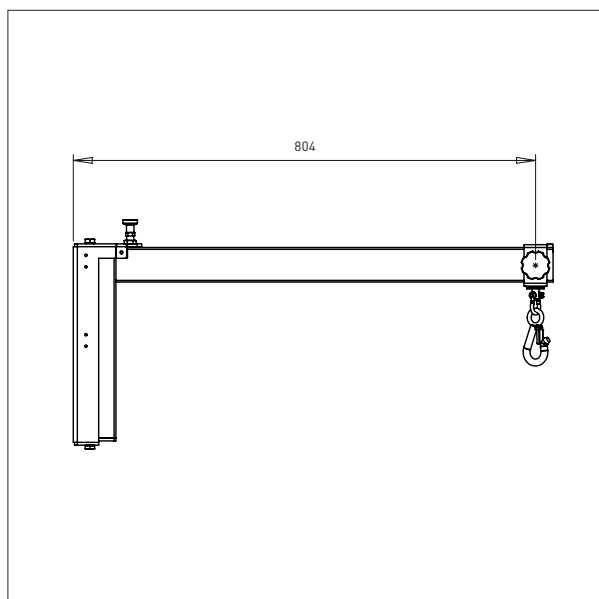



# IMPACT 80 / VÆRKTØJ

## TUBE

- Alle mål i mm

### TUBE

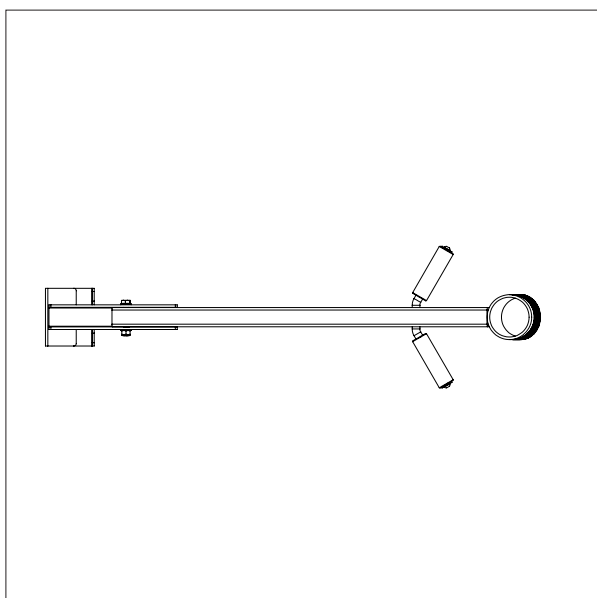
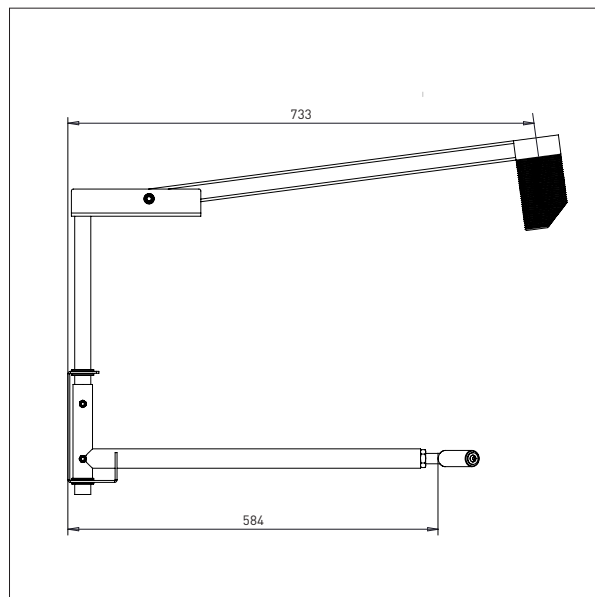
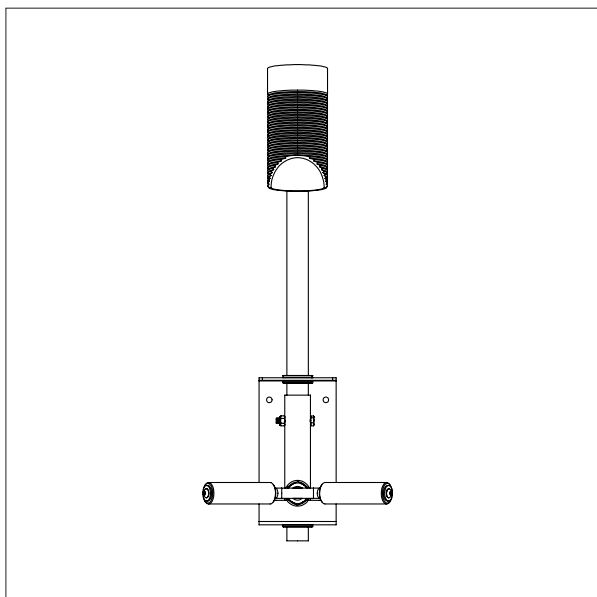

# IMPACT 80 / VÆRKTØJ

## RULLEMANIPULATOR

- Alle mål i mm

### RULLEMANIPULATOR - MRP1

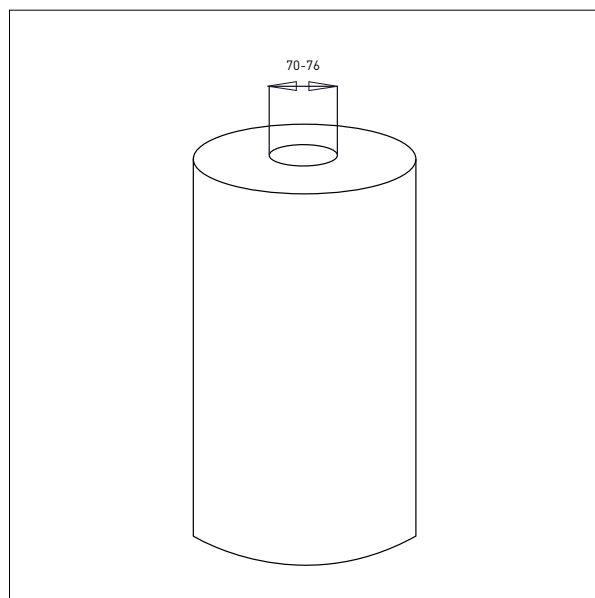
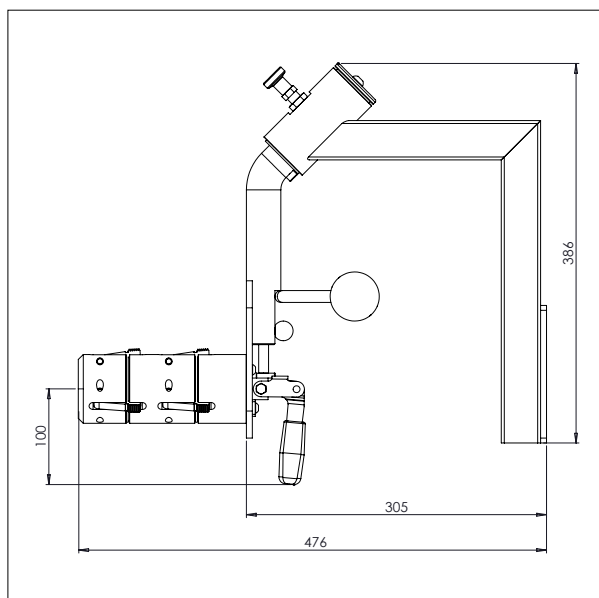
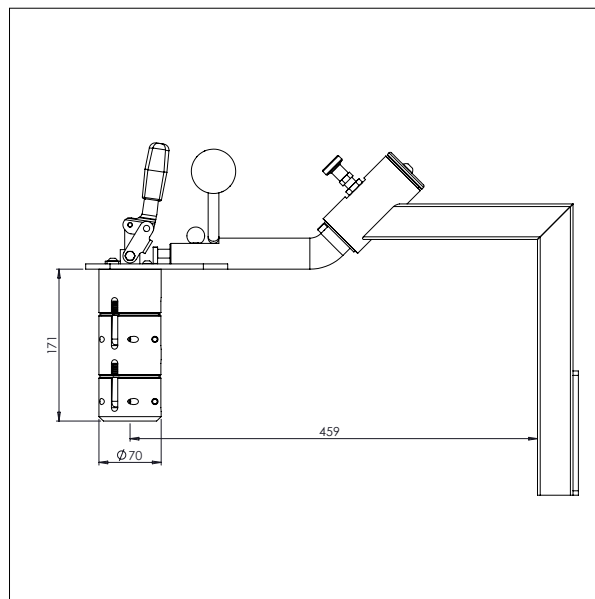
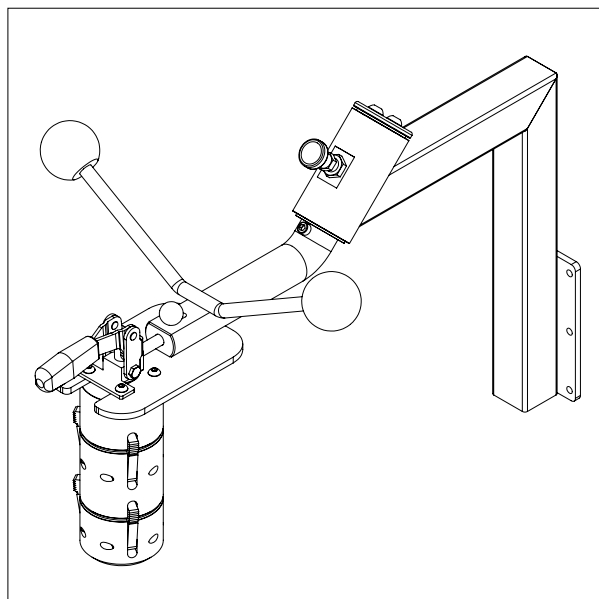

# IMPACT 80 / VÆRKTØJ

## RULLEMANIPULATOR

- Alle mål i mm

### RULLEMANIPULATOR - MRP2

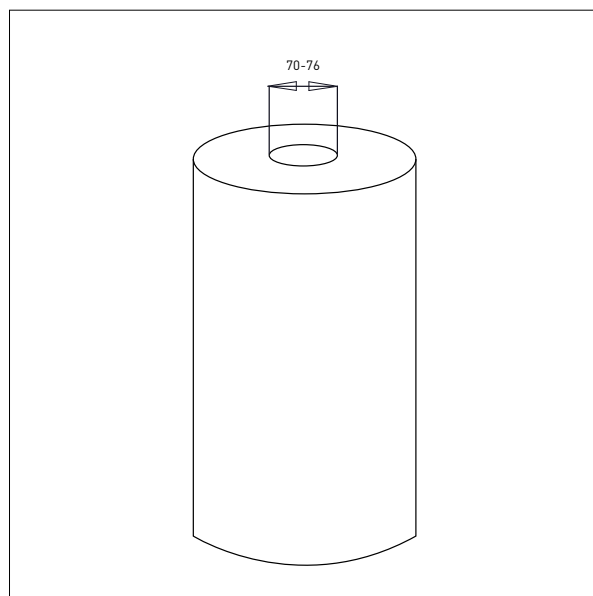
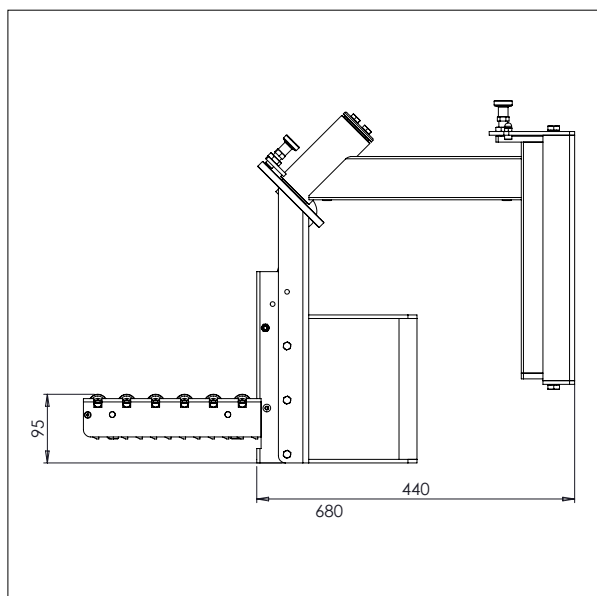
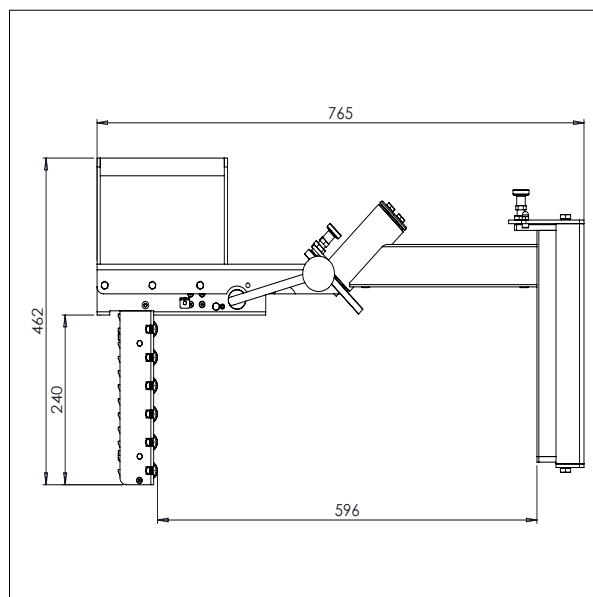
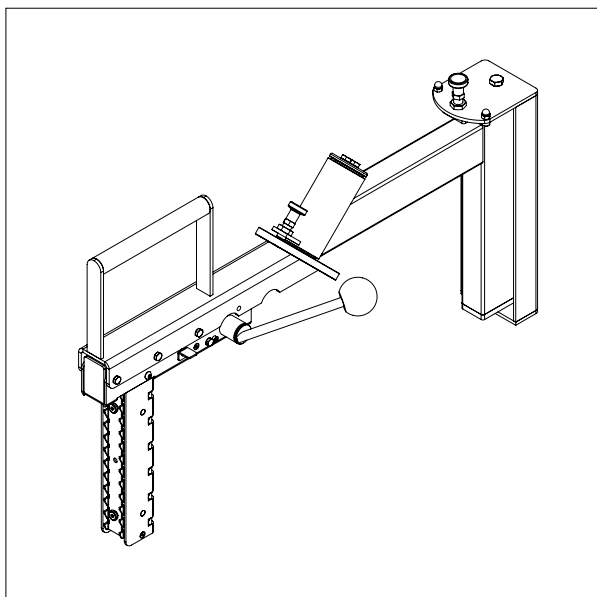

# IMPACT 80 / VÆRKTØJ

## DORNFORSTØRRER

- Alle mål i mm

### DORNFORSTØRRER - CL1

Til: Ø152 mm/6"

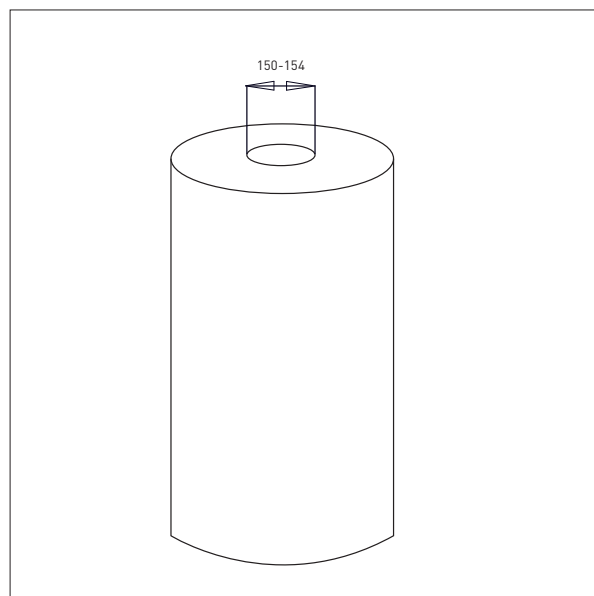
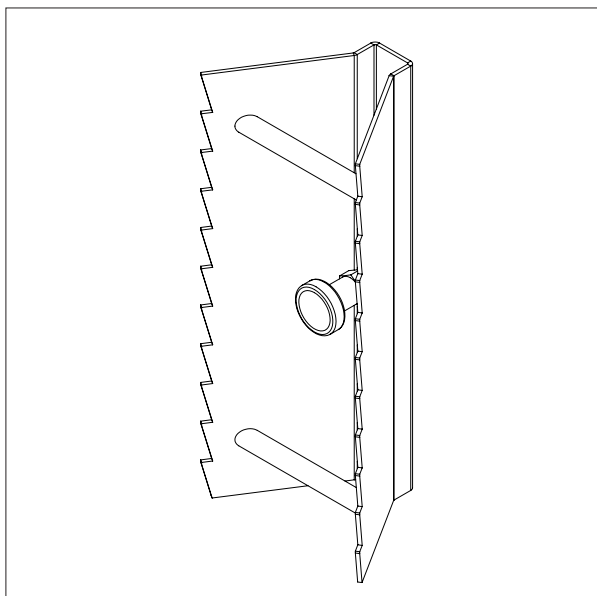

### DORNFORSTØRRER - CL2

Til: Ø254mm/10"

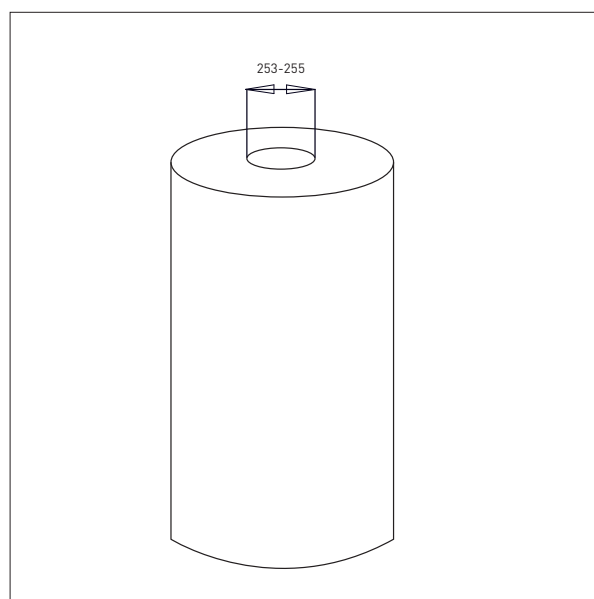
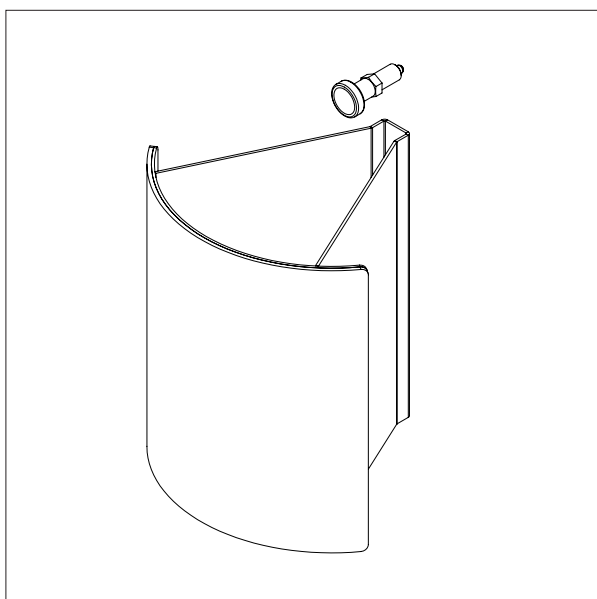

# IMPACT 80 / VÆRKTØJ

## RULLEMANIPULATOR

- Alle mål i mm

### RULLEMANIPULATOR - MRP3

